

120 x 120 x 38 mm

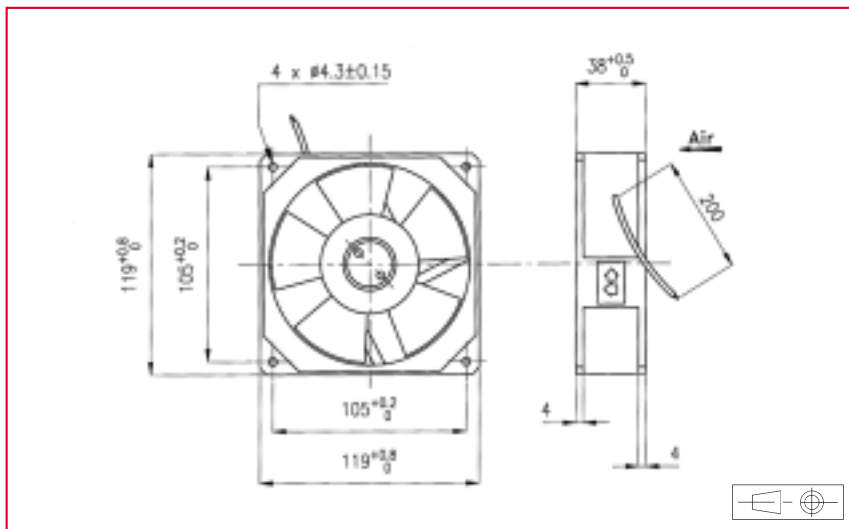
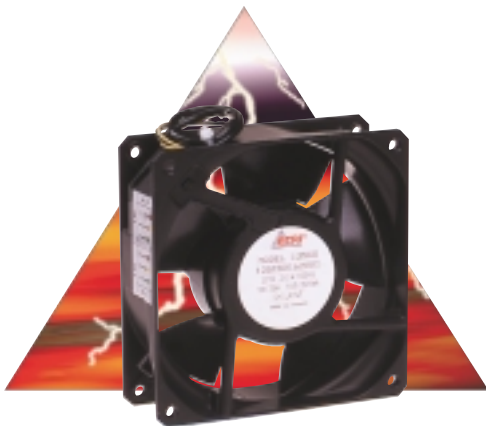

Approvals

See selection guide pages 15 to 26
GAMT 1 listed

Life expectancy

L-10 LIFE AT 40°C:

35 000 hours

For more details, see page 14

400 Hz Motor

Housing material: aluminium

Impeller material: plastic UL 94 VO

Weight: 0,530 kg

Bearing system: ball bearings

Connection: flying leads

Available with:

- speed sensor
- impedance protection

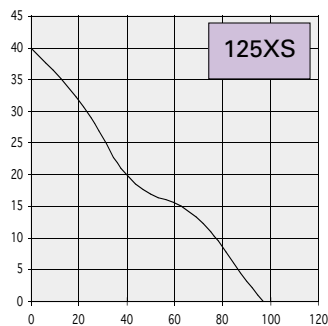
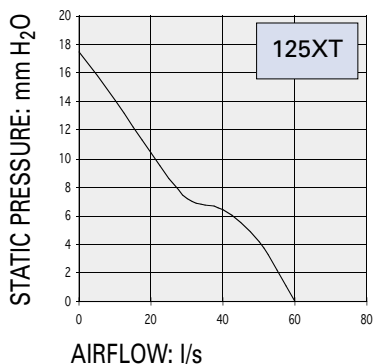

Part number	Nominal voltage	Airflow	Noise level	Nominal speed	Phases	Capacitor	Input power	Nominal current	Starting current	Operating temperature	
	V									l/s	dB(A)
125XT0162301	115	60	50	3600	3		15	140	220	- 10	70
125XT0162101	115	60	50	3750	1	0,15	19	170	200	- 10	70
125XT0160301	200	60	50	3600	3		15	75	115	- 10	70
125XT0160101	200	60	50	3750	1	0,05	19	100	120	- 10	70
125XS0162001	115	94	60	5700	3		32	415	1150	- 10	70
	115	94	60	5700	1	1,47	35	365	870	- 10	70
125XS0160001	200	94	60	5700	3		32	240	650	- 10	70
	200	94	60	5700	1	0,47	35	210	500	- 10	70

Additional versions:

Salt spray protected - shock and vibration protected - marine specifications - wide temperature range

Accessories:

See pages: 148, 150, 151, 152, 153, 154, 157, 161 and 162

400 Hz
Axial Fans

Non contractual document. Specifications are subject to change without prior notice. Pictures for information only. Edition N°2 / 01.