

120 x 120 x 38 mm

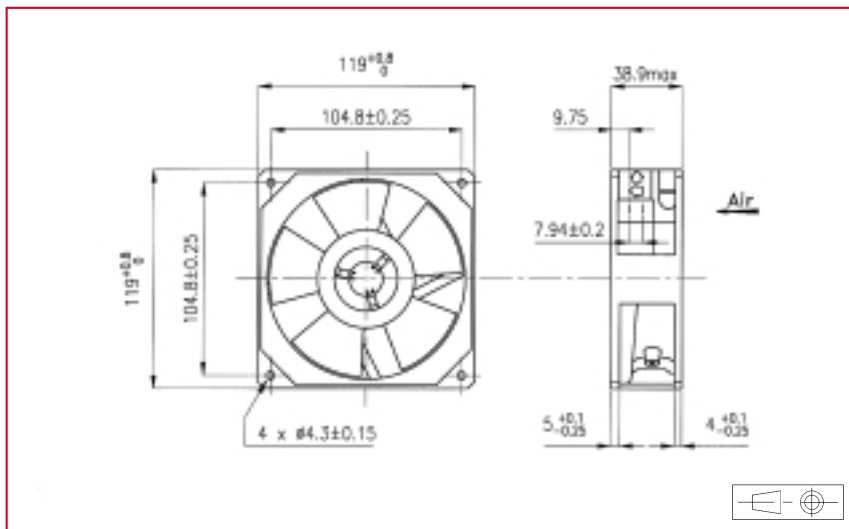
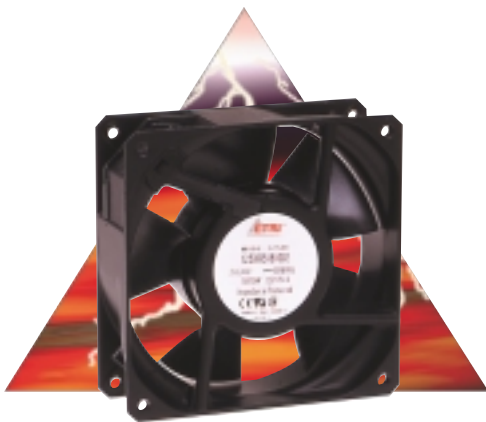

AC
Axial Fans

Approvals

See selection guide pages 15 to 26
GAMT 1 listed

Life expectancy

L-10 LIFE AT 40°C:

80 000 hours

For more details, see page 14

AC Motor

Electrical protection: impedance protected

Housing material: aluminium

Impeller material: plastic UL 94 VO

Weight: 0,560 kg

Available with:

- flying leads

- speed sensor

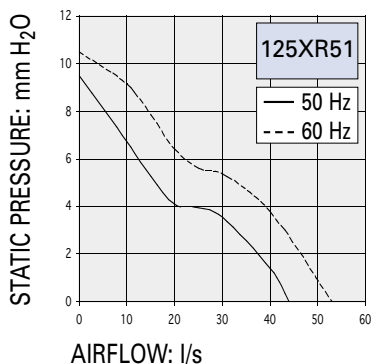

Non contractual document. Specifications are subject to change without prior notice. Pictures for information only. Edition N°2 / 01.

Part number	Nominal voltage	Airflow	Noise level	Nominal speed	Frequency	Phases	Capacitor	Input power	Nominal current	Starting current	Bearing system		Connection type		Operating temperature	
	V										l/s	dB(A)	RPM	Hz	µF	W
125XR5182002	115	44	43	2800	50	1		16	200	310	X			X	- 54	100
		53	48	3200	60	1		15	180	260	X			X	- 54	100
125XR5181002	208-240	44	43	2800	50	1		18	125	170	X			X	- 54	100
		53	48	3200	60	1		15	105	150	X			X	- 54	100

Additional versions:

Salt spray protected - shock and vibration protected - marine specifications - wide temperature range

Accessories:

See pages: 148, 150, 151, 152, 153, 154, 157, 161 and 162