

172 x 150 x 38 mm

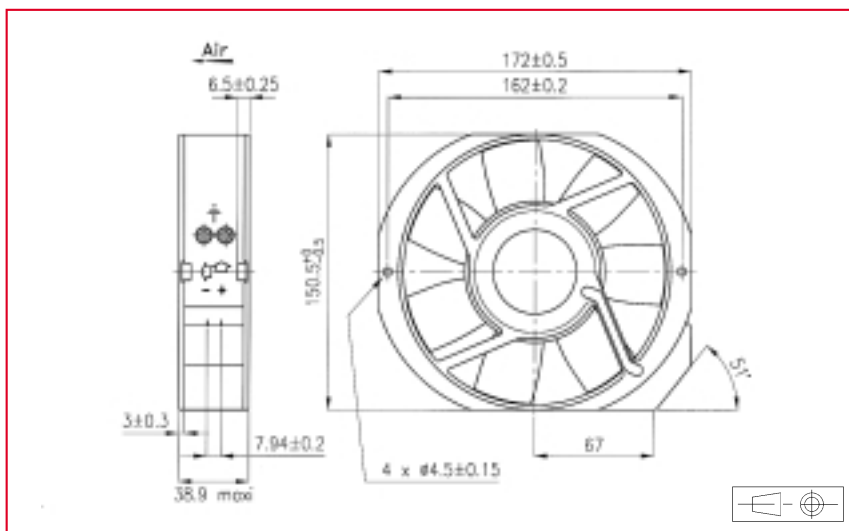
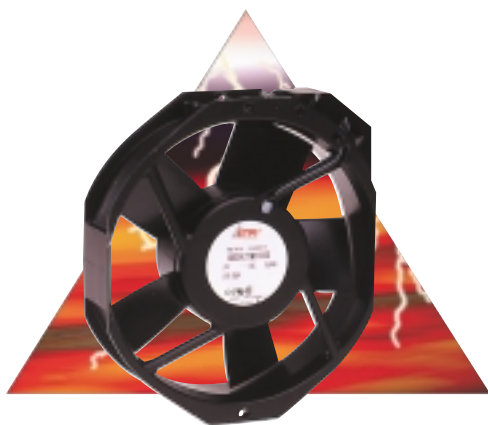

DC
Axial Fans

Approvals

See selection guide pages 15 to 26

Life expectancy

L-10 LIFE AT 40°C:

80 000 hours

For more details, see page 14

Brushless DC Motor

Electrical protection: integrated circuit

Housing material: zamak

Impeller material: plastic UL 94 VO

Weight: 770 g

Available with:

- speed sensor
- alarm
- flying leads
- IP 54

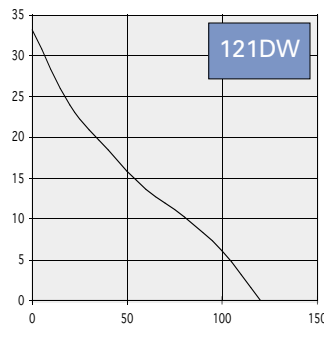
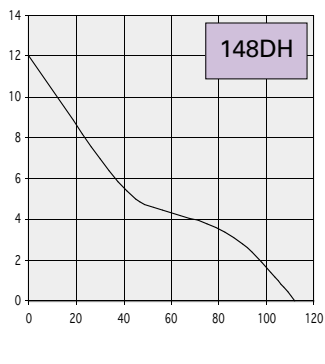
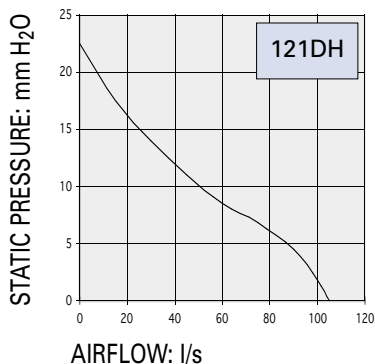

Non contractual document. Specifications are subject to change without prior notice. Pictures for information only. Edition N°2 / 01.

Part number	Nominal voltage	Airflow	Noise level	Nominal speed	Input power	Voltage range	Bearing system		Connection type		Operating temperature	
	V	l/s	dB(A)	RPM	W	V	Ball	Sleeve	Leads	Terminals	Min. °C	Max. °C
121DH2TM11200	24	105	62	4000	23	(19-28)	X			X	- 10	55
148DH1TM11000	12	110	58	3100	13	(9-15)	X			X	- 10	70
148DH2TM11000	24	112	58	3100	16	(19-28)	X			X	- 10	55
148DH4TM11000	48	112	58	3100	16	(40-57)	X			X	- 10	55
148DH9TM11207	110	112	58	3100	13	(76-140)	X			X	- 25	70
121DW2TM11200	24	120	66	4650	30	(19-26,5)	X			X	- 10	55
121DW9TM11200	28	120	66	4650	30	(19-31)	X			X	- 10	55

Additional versions:

Other speeds - salt spray protected

Accessories:

See pages: 150, 151, 154, 157, 161 and 162