

92 x 92 x 25 mm

DC
Axial Fans

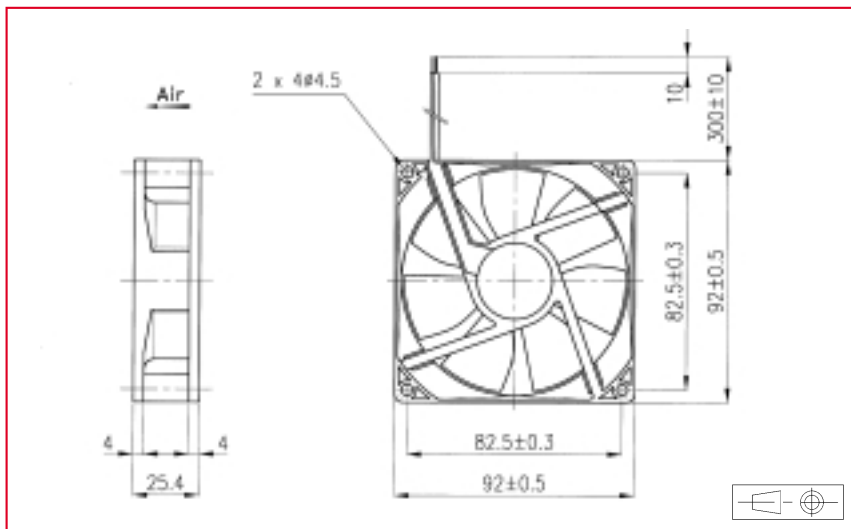

Approvals

See selection guide pages 15 to 26

Brushless DC Motor

Electrical protection: integrated circuit
Housing material: plastic UL 94 VO
Impeller material: plastic UL 94 VO
Weight: 99 g

Available with:

- variable speed
- speed sensor
- alarm

Life expectancy

L-10 LIFE AT 40°C:
80 000 hours (ball bearings)
50 000 hours (sleeve bearings)
For more details, see page 14

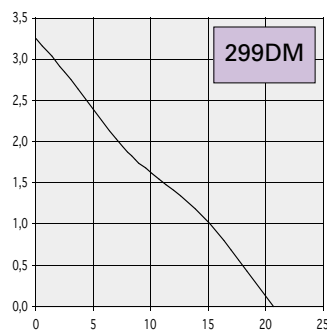
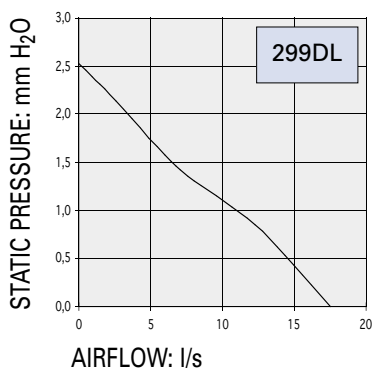

Part number	Nominal voltage	Airflow	Noise level	Nominal speed	Input power	Voltage range	Bearing system		Connection type		Operating temperature	
	V						I/s	dB(A)	RPM	W	V	Ball
299DL1LP11000	12	17,5	25	2100	0,8	(7-13,8)	X		X		- 10	70
299DL1LP31000	12	17,5	25	2100	1,0	(7-13,8)		X	X		- 10	60
299DL2LP11000	24	17,5	25	2100	1,4	(14-27,6)	X		X		- 10	70
299DL2LP31000	24	17,5	25	2100	1,7	(20,4-27,6)		X	X		- 10	60
299DL4LP11000	48	17,5	25	2100	2,4	(38-56)	X		X		- 10	70
299DM1LP11000	12	20,7	30	2450	1,3	(7-13,8)	X		X		- 10	70
299DM1LP31000	12	20,7	30	2450	1,6	(7-13,8)		X	X		- 10	60
299DM2LP11000	24	20,7	30	2450	1,9	(14-27,6)	X		X		- 10	70
299DM2LP31000	24	20,7	30	2450	1,9	(20,4-27,6)		X	X		- 10	60
299DM4LP11000	48	20,7	30	2450	2,4	(38-56)	X		X		- 10	70

Additional versions:

Higher speeds (see page 53)

Accessories:

See pages: 148, 150, 151, 153, 154 and 162

Non contractual document. Specifications are subject to change without prior notice. Pictures for information only. Edition N°2 / 01.