

ø 172 x 50 mm

New !

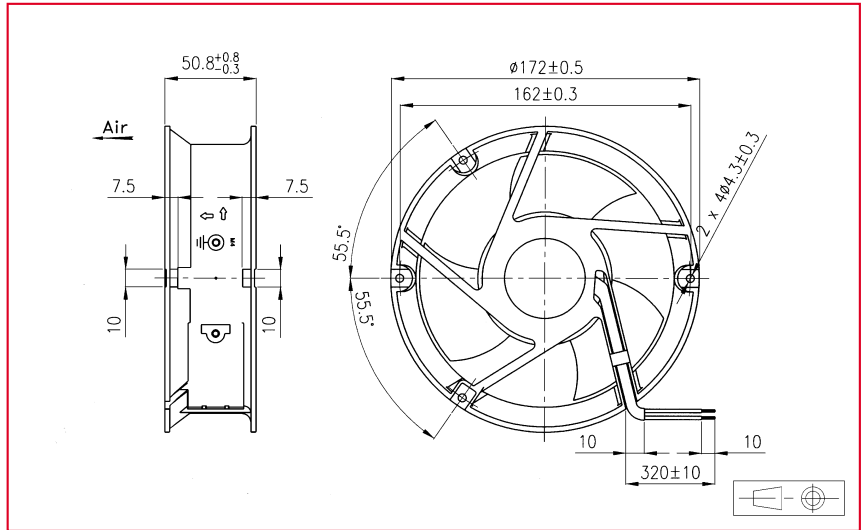

DC
Axial Fans

Approvals

See selection guide pages 15 to 26

Life expectancy

L-10 LIFE AT 40°C:

80 000 hours

For more details, see page 14

Brushless DC Motor

Electrical protection: impedance protected

Housing material: aluminium

Impeller material: plastic UL 94 VO

Weight: 840 g

Available with:

- speed sensor

- alarm

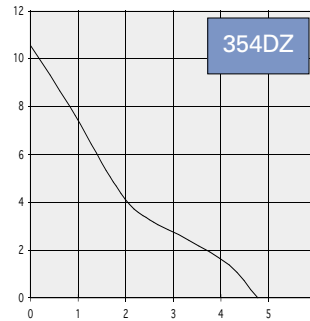
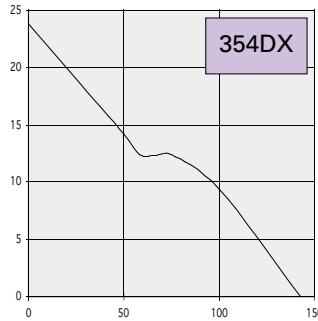
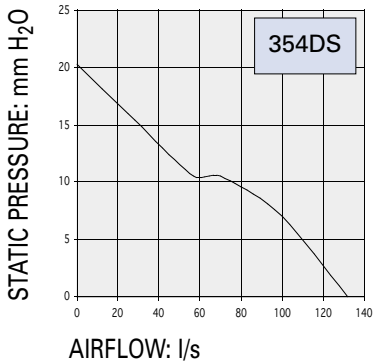

Non contractual document. Specifications are subject to change without prior notice. Pictures for information only. Edition N°2 / 01.

Part number	Nominal voltage	Airflow	Noise level	Nominal speed	Input power	Voltage range	Bearing system		Connection type		Operating temperature	
	V						I/s	dB(A)	RPM	W	V	Ball
354DS1LM11000	12	132,0	57,5	3700	25,3	(8-14)	X		X		- 10	70
354DS2LM11000	24	132,0	57,5	3700	20,4	(12-28)	X		X		- 10	70
354DS4LM11000	48	132,0	57,5	3700	23,5	(24-56)	X		X		- 10	70
354DX2LM11000	24	142,7	60	4000	26,4	(12-28)	X		X		- 10	70
354DX4LM11000	48	142,7	60	4000	30,7	(24-56)	X		X		- 10	70
354DZ2LM11000	24	153,3	63	4300	32,9	(12-28)	X		X		- 10	70

Additional versions:
Lower speeds (see page 66)

Accessories:
See pages: 150, 151, 154, 157 and 162