

165 x 181 x 190 mm

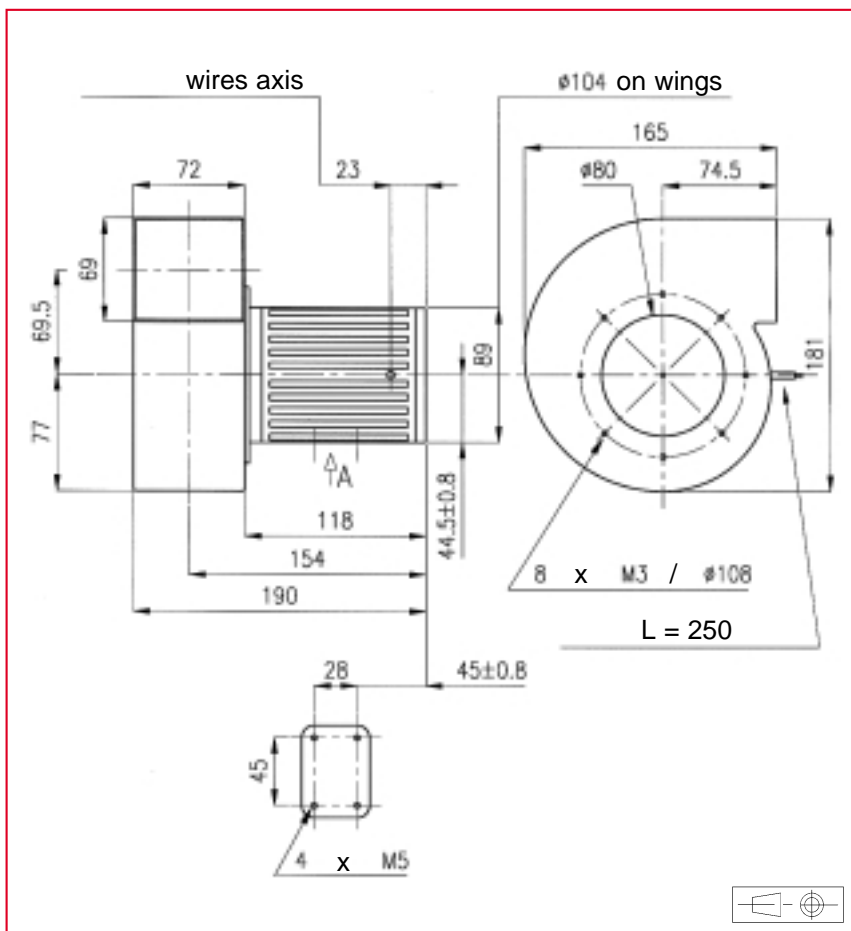

Approvals

See selection guide pages 15 to 26
GAMT 1 listed

Life expectancy

L-10 LIFE AT 40°C:
25 000 hours
For more details, see page 14

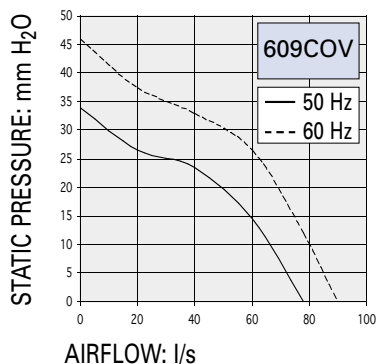

AC Motor

Housing material: steel plate
Wheel material: steel plate
Weight: 3,6 kg
Bearing system : ball bearings

Connection : flying leads

Available with:

- safety switch

Part number	Nominal voltage	Airflow	Noise level	Nominal speed	Frequency	Phases	Capacitor (not included)	Input power	Nominal current	Starting current	Operating temperature	
	V	l/s	dB(A)	RPM	Hz		µF	W	mA	mA	Min. °C	Max. °C
609COV016DC13	220	79	65	2800	50	3		60	260	1250	- 10	70
	380	79	65	2800	50	3		60	150	750	- 10	70
	220	89	68	3200	60	3		88	295	1150	- 10	70
	380	89	68	3200	60	3		88	170	700	- 10	70
	220	79	65	2800	50	1	4,7	66	285	1100	- 10	70
	380	79	65	2800	50	1	1,47	66	160	650	- 10	70
	220	89	68	3200	60	1	4,7	97	440	1000	- 10	70
	380	89	68	3200	60	1	1,47	97	250	600	- 10	70

Additional versions:

Salt spray protected - shock and vibration protected - marine specifications - wide temperature range

Accessories:

See pages: 157, 160 and 163

Non contractual document. Specifications are subject to change without prior notice. Pictures for information only. Edition N°2 / 01.