

200 x 222,5 x 331 mm

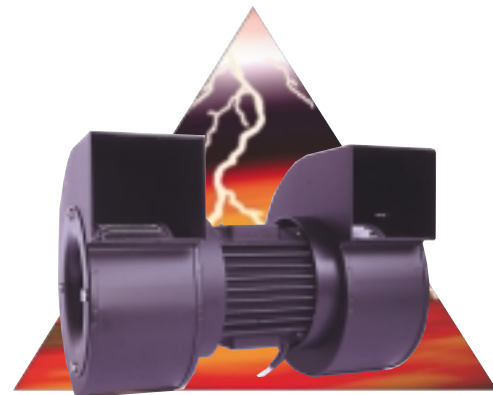
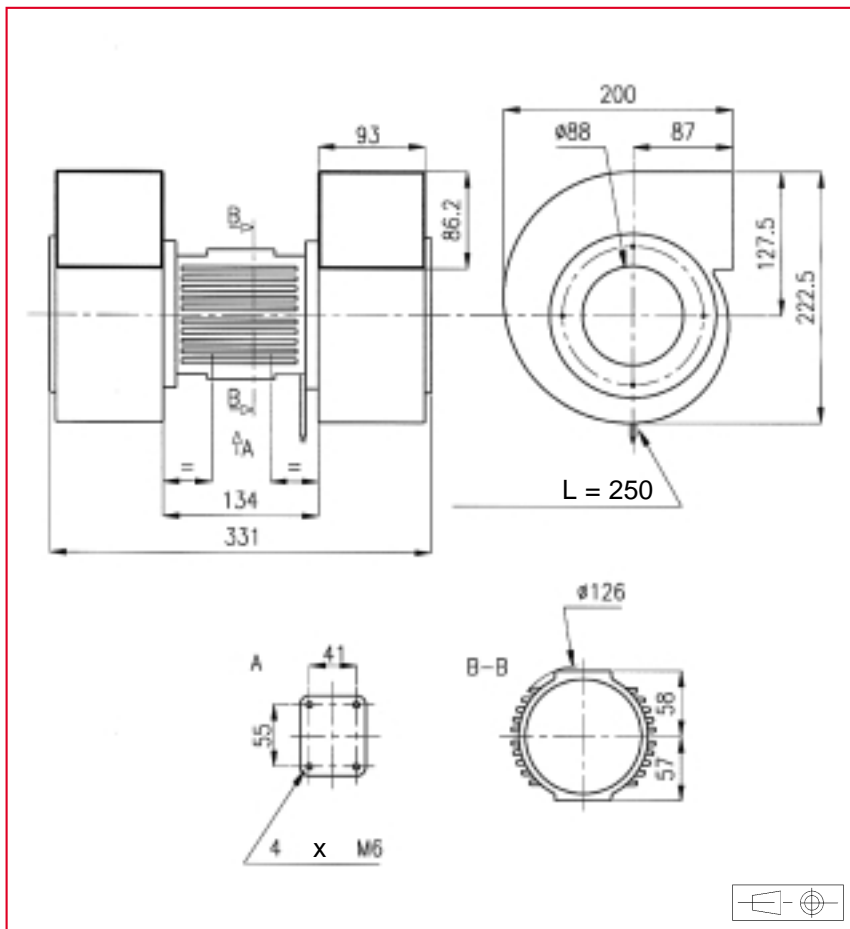

Approvals

See selection guide pages 15 to 26
GAMT 1 listed

Life expectancy

L-10 LIFE AT 40°C:

25 000 hours

For more details, see page 14

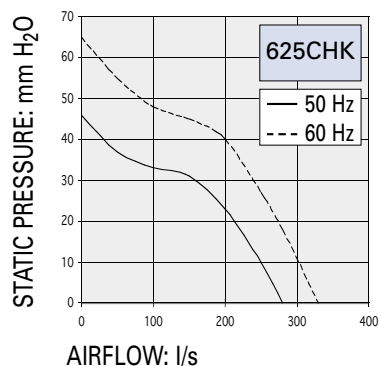

AC Motor

Housing material: steel plate
Wheel material: steel plate
Weight: 7,5 kg
Bearing system: ball bearings

Connection: flying leads

Part number	Nominal voltage	Airflow	Noise level	Nominal speed	Frequency	Phases	Capacitor (not included)	Input power	Nominal current	Starting current	Operating temperature	
	V										I/s	dB(A)
625CHK216DC13	220	280	67	2850	50	3		250	1300	6300	- 10	70
	380	280	67	2850	50	3		250	750	3650	- 10	70
	220	320	71	3300	60	3		350	1300	5850	- 10	70
	380	320	71	3300	60	3		350	750	3400	- 10	70
	220	280	67	2850	50	1	14,7	245	1400	5400	- 10	70
	380	280	67	2850	50	1	5	245	800	3150	- 10	70
	220	320	71	3300	60	1	14,7	355	1700	4950	- 10	70
	380	320	71	3300	60	1	5	355	1150	2900	- 10	70

Additional versions:

Salt spray protected - shock and vibration protected - marine specifications - wide temperature range

Accessories:

See pages: 157, 160 and 163

Non contractual document. Specifications are subject to change without prior notice. Pictures for information only. Edition N°2 / 01.