

# 113 x 113 x 88,5 mm

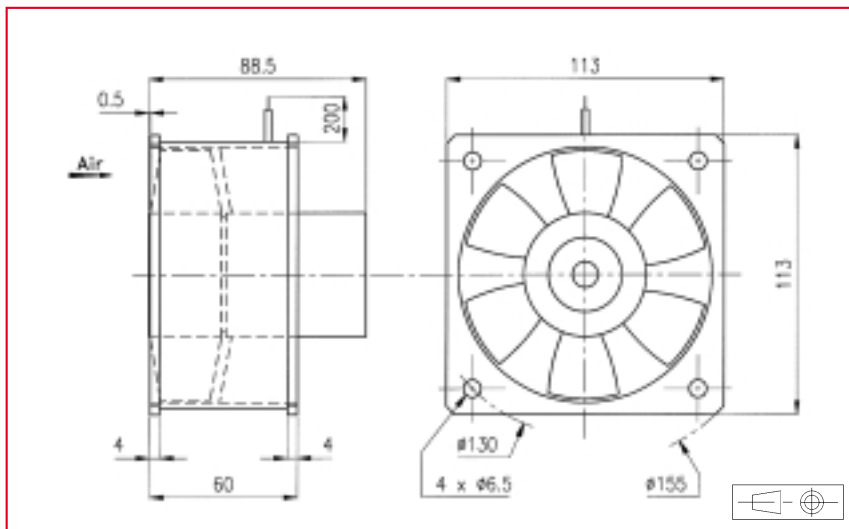
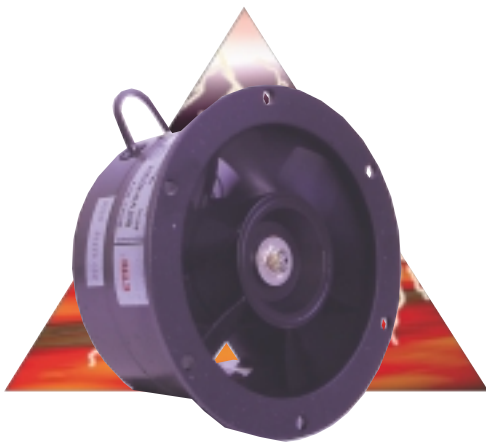

### Approvals

See selection guide pages 15 to 26  
GAMT 1 listed

### Life expectancy

L-10 LIFE AT 40°C:

**35 000 hours**

For more details, see page 14

### 400 Hz Motor

Housing material: aluminium

Impeller material: aluminium

Weight: 0,940 kg

Bearing system: ball bearings

Connection: flying leads

### Available with:

- round housing

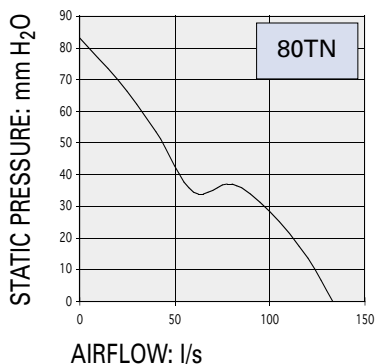

Non contractual document. Specifications are subject to change without prior notice. Pictures for information only. Edition N°2 / 01.

400 Hz  
Axial Fans

Part number	Nominal voltage	Airflow	Noise level	Nominal speed	Phases	Capacitor <i>(not included)</i>	Input power	Nominal current	Starting current	Operating temperature	
	V	l/s	dB(A)	RPM		µF	W	mA	mA	Min. °C	Max. °C
80TN0562C13	115	135	76	9700	3		153	1150	2800	- 10	70
	115	135	76	9700	1	4,7	147	1400	2350	- 10	70
80TN0560C13	200	135	76	9700	3		153	650	1600	- 10	70
	200	135	76	9700	1	1,47	147	785	1350	- 10	70

### Additional versions:

Salt spray protected - shock and vibration protected - marine specifications - wide temperature range

### Accessories:

See pages: 157 and 163