

ø 180 x 87 mm

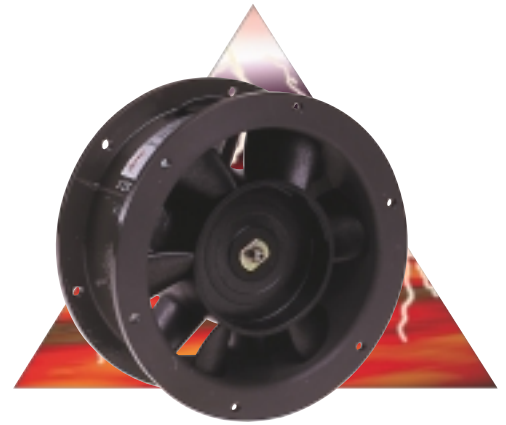
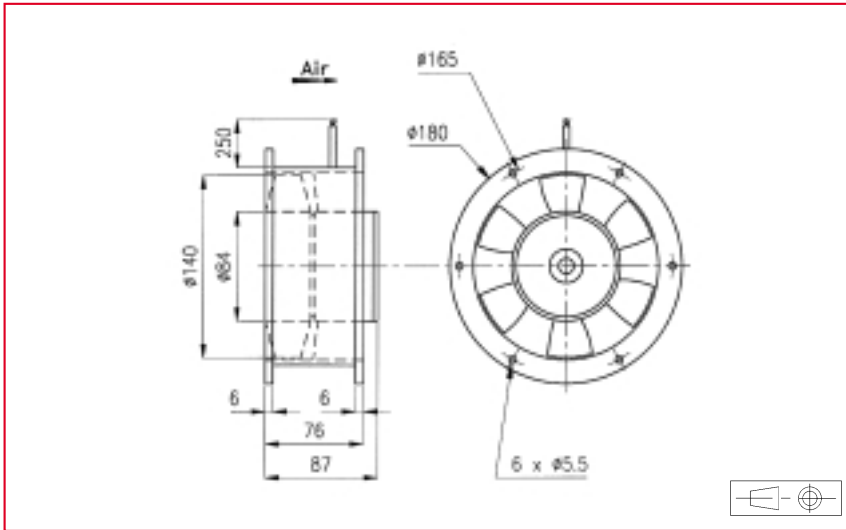

Approvals

See selection guide pages 15 to 26
GAMT 1 listed

Life expectancy

L-10 LIFE AT 40°C:
25 000 hours
For more details, see page 14

AC Motor

Housing material: aluminium
Impeller material: plastic
Weight: 2,1 kg
Bearing system: ball bearings

Available with:

- safety switch
- aluminium impeller

High Performance

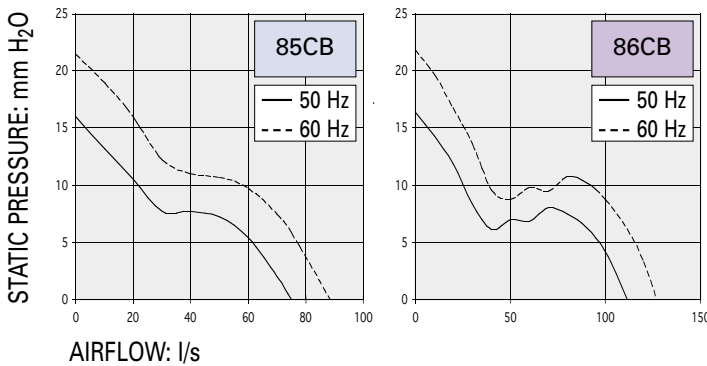

Part number	Nominal voltage	Airflow	Noise level	Nominal speed	Frequency	Phases	Capacitor	Input power	Nominal current	Starting current	Connection type		Operating temperature	
	V	l/s	dB(A)	RPM	Hz		(not included)	W	mA	mA	Leads	Terminals	Min. °C	Max. °C
85CB016DC13	220	75	57	2850	50	3		20	110	320	X		-10	70
	380	75	57	2850	50	3		20	65	185	X		-10	70
	220	88	61	3300	60	3		23	95	300	X		-10	70
	380	88	61	3300	60	3		23	55	175	X		-10	70
	220	75	57	2850	50	1	1,47	20	110	260	X		-10	70
	380	75	57	2850	50	1	0,47	20	65	150	X		-10	70
	220	88	61	3300	60	1	1,47	24	115	250	X		-10	70
	380	88	61	3300	60	1	0,47	24	70	145	X		-10	70
86CB016DC13	220	111	56	2800	50	3		35	170	470	X		-10	70
	380	111	56	2800	50	3		35	100	275	X		-10	70
	220	127	60	3200	60	3		41	150	440	X		-10	70
	380	127	60	3200	60	3		41	90	255	X		-10	70
	220	111	56	2800	50	1	2,2	34	180	400	X		-10	70
	380	111	56	2800	50	1	0,69	34	105	235	X		-10	70
	220	127	60	3200	60	1	2,2	42	200	375	X		-10	70
	380	127	60	3200	60	1	0,69	42	115	220	X		-10	70

Additional versions:

Salt spray protected - shock and vibration protected - marine specifications - wide temperature range - other voltages (consult factory)

Accessories:

See pages: 155, 158, 157, 159 and 163