

# 120 x 120 x 25 mm

400 Hz Axial Fans

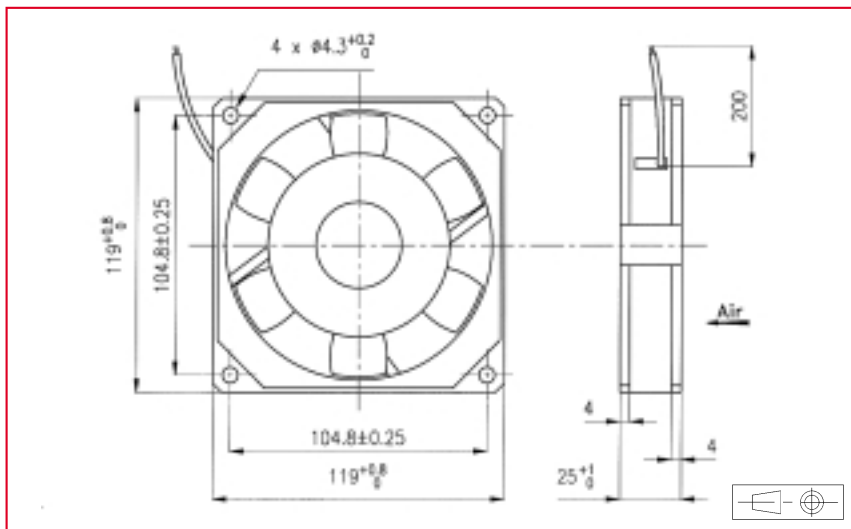

### Approvals

See selection guide pages 15 to 26  
GAMT 1 listed

### Life expectancy

L-10 LIFE AT 40°C:  
**35 000 hours**  
For more details, see page 14

### 400 Hz Motor

Housing material: zamak  
Impeller material: plastic UL 94 VO  
Weight: 0,500 kg  
Bearing system: ball bearings

Connection: flying leads

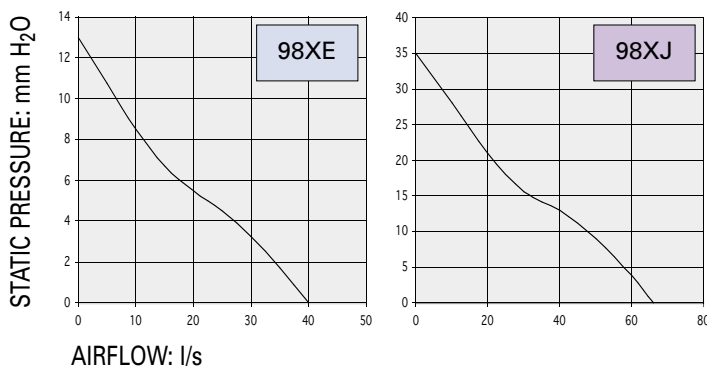

Part number	Nominal voltage	Airflow	Noise level	Nominal speed	Phases	Capacitor	Input power	Nominal current	Starting current	Operating temperature	
	V									l/s	dB(A)
98XE0162001	115	40	52	3500	1	0,15	13	113	135	- 10	70
98XE0160001	200	40	52	3500	1	0,05	13	70	80	- 10	70
98XJ0162001	115	66	65	5500	3	1	30	310	490	- 10	70
	115	66	65	5500	1		30	310	610	- 10	70
98XJ0160001	200	66	65	5500	3	0,32	30	180	280	- 10	70
	200	66	65	5500	1		30	180	350	- 10	70

### Additional versions:

Salt spray protected - shock and vibration protected - marine specifications - wide temperature range

### Accessories:

See pages: 148, 150, 151, 152, 153, 154, 157, 161 and 162

Non contractual document. Specifications are subject to change without prior notice. Pictures for information only. Edition N°2 / 01.